

Phone: 044-24323800



Fax No: 044-24323900

भारत सरकार/ GOVT. OF INDIA
वित्त मंत्रालय, राजस्व विभाग
MINISTRY OF FINANCE, DEPARTMENT OF REVENUE
केंद्रीय वस्तुओं, सेवा कर और केंद्रीय उत्पाद शुल्क आयुक्त का कार्यालय - लेखा परीक्षा-II
OFFICE OF THE COMMISSIONER OF GOODS AND SERVICE TAX & CENTRAL EXCISE
AUDIT II COMMISSIONERATE
692, एम. एच. यू. कॉम्प्लेक्स, नन्दनम, चेन्नै - 600035
692, M. H. U. COMPLEX, NANDANAM, CHENNAI - 600 035

C. No. I/22/8/2016-GST-Audit-II

Dated: 06/10/2017

E-TENDER NOTICE - 0002/2017

Notice for inviting Tender for supply and installation of modular workstation in the Office of the Commissioner of GST & Central Excise, Audit-II, 7thFloor, Nandanam, Chennai-600035-Reg.

Online tenders are invited from reputed firm/Company/Manufacturer for supply and installation of modular workstation in the Office of the Commissioner of GST & Central Excise Audit-II Commissionerate, 7th Floor, MHU Complex, Nandanam, Chennai-600035.

2. Last date for uploading the tender documents by bidders duly completed in all respect is at 16/10/2017 at 12.00 PM

3. The lump sum amount to be quoted for the entire work by the tenderers shall include all taxes as applicable at the time of awarding of contract and during the execution of work till completion.

4. The Commissioner of GST & Central Excise, Audit-II, Chennai-35, reserves the right to reject or accept any application/tender without assigning any reason.

5. Any inquiries by the tenderer may be obtained from the undersigned on any working day from 1100 hours to 1700 hours between 06/10/2017 to 13/10/2017. This tender notice is also available on the official website at www.cbec.gov.in.

-Sd/-

B.S.Balavinayagam
Assistant Commissioner (Admin)
GST -Audit-II, Chennai-35.

Note : The complete tender documents viz. Technical bid and Financial bid along with scope of work, terms and conditions and tender process can be accessed & downloaded from

Portal <http://eprocure.gov.in/eprocure/app>

(Tender id: 2017_DREV_253340_1)

Please check regularly the website for any changes/modification/amendment in the Tender Enquiry. This Tender Enquiry (TE) is being issued with no financial commitment and department reserves the right to change or vary any part thereof at any stage. The department also reserves the right to withdraw the tender enquiry, should it become necessary at any stage.

Phone: 044-24323800



Fax No: 044-24323900

भारत सरकार/ GOVT. OF INDIA
वित्त मंत्रालय, राजस्व विभाग
MINISTRY OF FINANCE, DEPARTMENT OF REVENUE
केंद्रीय वस्तुओं, सेवा कर और केंद्रीय उत्पाद शुल्क आयुक्त का कार्यालय - लेखा परीक्षा-II
OFFICE OF THE COMMISSIONER OF GOODS AND SERVICE TAX & CENTRAL EXCISE
AUDIT II COMMISSIONERATE
692, एम. एच. यू. कॉम्प्लेक्स, नन्दनम, चेन्नै - 600035
692, M. H. U. COMPLEX, NANDANAM, CHENNAI - 600 035

C. No. I/22/8/2016-GST-Audit-II

Dated: 06/10/2017

Tender Documents

1. Online tenders are invited from reputed firm/Company/Manufacturer for supply and installation of modular structures/ Work station in the Office of the Commissioner of GST & Central Excise, Audit-II, Nandanam, Chennai-600035.

2. Tender Process and uploading of Tender documents: -

The bid / tender will consist of two parts – Technical bid and Financial bid. The bid of all parties whose rates quoted by them finds mention in their Technical Bid shall be rejected forthwith. All information sought under terms and conditions and other information to be supplied is to be given in Technical Bid while the price quoted by them will be mentioned only in the Financial Bid.

- (i) The offers / bids received incomplete and / or filed after the due date and time shall be summarily rejected.
- (ii) The Technical Bids shall be opened on 17/10/2017 at 02.00 PM in the presence of bidder or their authorized representative with authority letter, if they appear.
- (iii) The financial bids of only those parties shall be opened whose Technical Bids are found to be eligible.
- (iv) The department reserves the right to accept or reject any or all tenders without assigning any reason. In case of any dispute of any kind and in respect of whatsoever, the decision of the Commissioner of GST & Central Excise, Audit-II, Nandanam, Chennai-600035, will final and binding.

3. Authenticity of the tender document: -

Every page of tender document along with enclosures must be signed by the bidder.

4. **Tender Document** : The tender documents containing terms and conditions alongwith prescribed proforma / format for furnishing required information / details can be obtained from the Assistant Commissioner (Admin), GST-Audit-II, No.692, Anna Salai, 6th Floor, MHU Complex, Nandanam, Chennai-600035, on any working day from 06/10/2017 to 13/10/2017 Alternatively the tender can be downloaded from the portal <https://eprocure.gov.in/eprocure/app> and <http://www.cbec.gov.in/htdocs-cbec/tender/tenders-idx>

5. **Earnest Money Deposit [EMD]:**

- (i) Tender documents must be accompanied with non-interest bearing Earnest Money of Rs.75,000 /- (Rs. Seventy Five Thousand only) in form of Demand Draft in favour of the Commissioner of GST & Central Excise, Audit-II, Chennai payable at Chennai, failing which tender will be summarily rejected.
- (ii) Cheques will not be accepted.
- (iii) No earnest money deposit will be accepted after the due date and time of submission of tender document.
- (iv) Earnest money deposited with other Tender will not be adjustable with this Tender.
- (v) No bank commission or interest will be paid on the earnest money deposit.
- (vi) If a bidder withdraws its offer after opening of Technical Bid or Financial Bid before award of tender to other valid tenderer, the earnest money deposited by them will be forfeited.
- (vii) If a successful bidder fails to deposit requisite amount towards the Performance Security within specified time as per intimation / request of Commissioner of GST & Central Excise, Audit-II, Chennai, the earnest money deposited will be forfeited.
- (viii) Central / State Government and Central / State Government Undertakings are exempted from deposit of Earnest Money.

6. **Performance Security: -**

The successful tenderer will be wholly and solely responsible for any damage/levy/claim and will be liable to pay the said damage/levy/claim. In this context, the successful bidder will deposit Rs. 75,000/- (Rs. Seventy five thousand only) as performance security which is non-interest bearing in the shape of Bank Draft / Bank Guarantee issued by a Nationalized Bank only drawn in favour of the Commissioner of GST & Central Excise, Audit-II, Chennai

7. **Refund of Earnest Money Deposit & Performance Security: -**

- (i) Earnest money deposited by the unsuccessful bidder will be refunded to bidder at the earliest after finalization of the tender. Earnest money

will be refunded to the successful bidder on receipt of Performance Security.

- (ii) Further, the performance security will be refunded/ returned to the successful bidder after successful execution of the work.
- (iii) The Performance Security will be forfeited in case of unsatisfactory performance of the successful bidder. The decision of the Commissioner of GST & Central Excise, Audit-II, Chennai on this account will be final and binding on successful bidder.

8. Rates: -

- (i) Rate/bid/offer must be without any condition, assumption, qualification, reservation or variation. Rate/ bid/offer must be mentioned in prescribed proforma in figures and in words in respect of each item separately. In case of any discrepancy, rates quoted in words will prevail. Conditional tender offer or offer at variance from prescribed specification would be ineligible to compete for the tender. Prices and price components shall be firm and shall not be subject to any price variation or adjustment on account of any price escalations throughout the execution of the contract.
- (ii) The bidder shall quote their rate inclusive of all taxes and installation charges.
- (iii) The rates have to be shown separately in the financial bid (Annexure B) i.e in BOQ Excel sheet.

9. Subletting of Contract: -

The successful bidder shall not be allowed to sublet / subcontract the contract to any other contractor.

10. Completion Period :-

- (i) Contract has to completed within a period of 30 days from date of supply order/Award of work.
- (ii) Liquidated damage (LD) will be charged @ of 2.50% per completed week or part thereof for delay subject to maximum of 10% of the value of work order.

11. Prescribed format / proforma: -

- (i) **Annexure – A** and **Annexure – B** are to be duly filled by the bidder in respect of each item.
- (ii) An affidavit in prescribed proforma i.e. **Annexure – C** regarding non-blacklisting or non-convicting by any court of law is to be duly submitted.
- (iii) The successful bidder has to submit a Demand Draft or a bank guarantee towards performance security in the prescribed proforma i.e. **Annexure – D**.

12. Documents required to be attached with technical bid:

- (i) Design of layout clearly showing dimensions. Any variation in size from the dimensions quoted in Tender Notice must be specifically spell out.
- (ii) Complete technical specifications along with brochure / photograph/ coloured picture if any.
- (iii) A Copy of Terms & conditions **duly signed** by the bidder (including warranty and after sales service except price schedule).
- (iv) Demand Draft / Bank Guarantee of Rs.75,000/- (Rs. Seventy five thousand only) in favour of the Commissioner of GST & Central Excise, Audit-II Chennai payable at Chennai as Earnest Money Deposit.
- (v) GST Registration Certificate
- (vi) All other supporting documents as required in the tender shall be attached.
- (vii) Signed declaration as given on **Annexure –C** of the bid document.
- (viii) Experience certificate (for details of similar contracts handled by the tendering company /firm/agency for government departments/PSUs /Banks/other Pvt.Firms/Companies during the last three years. (List should be enclosed in technical bid).
- (ix) Balance sheet for the last 3 financial years.

13. **Eligibility criteria for bidder:** -

- (i) Only those firms/Company/ Manufacturers will be eligible to tender their bids whose annual turnover is atleast Rs.25 Lakhs or above in each of the last three financial years.
- (ii) Only those firms who have Experience of having successfully completed similar works during last 7 years ending last day of month ending September 2017 should be either of the following: -
 - a. Three similar completed works costing not less than the amount equal to Rs.20 Lakhs. Or
 - b. Two similar completed works costing not less than the amount equal to Rs.25 Lakhs. Or
 - c. One similar completed work costing not less than the amount equal to Rs.40 Lakhs.
- (iii) The firms /Company/ Manufacturers should have executed such orders in at least for two government offices /PSU / Pvt.Firms/ Companies in the last 3 years. The authorized dealer/ franchise / distributor may submit bids on behalf of the firms/ Company/Manufacturer along with valid authorization letter issued by the firms/ Company/Manufacturers to the bidder for this particular tender, to do so. Preference would be given to manufacturers registered with National Small Industries Corporation (NSIC), Ministry of Micro Small and Medium Enterprises (MSME). [supporting documents to be attached]
- (iv) The bidder should have capability to provide after sales service during warranty period and should be in a position to offer annual

maintenance contract thereafter. The bidder should have registered branch office/Dealers network in Chennai. List of the addresses of the branch/ Authorized dealers to be attached.

14. Validity of the offer / bid: -

The offer / bid of the bidder will be valid for at least for 3 months from the date of opening of Technical bid.

15. Details of tendered items: -

The supply and installation of modular workstation/renovation is to be carried out as per plan given in drawings annexed as Annexure E of this tender document.

SCHEDULE OF QUANTITIES			
SL.no	Description	Qty	Unit
1	Partitions		
1.01	Fixing 75mm thick wooden partitions strongly anchored/ fixed to true ceiling using aluminium hollow section as main vertical members @ 2 feet intermittent spacing and horizontal secondary members @ 4 feet intermittent spacing, fixing of 8 mm thick commercial ply on both sides finished with 1.0 mm thick approved laminate till false ceiling bottom. Laminate colour as per depts choice. (Make: Plywood- Greenply, Sharon, Century or equivalent. Laminate: Merino/ Green or equivalent)	2600.00	Sq.ft
2	Doors & Door Frames		
2.01	Providing & Fixing of 35mm flush doors finished with laminates, Including all necessary hardware like BB Hinges, Door Closer, Handle & Lock. Doors to have 100*40 mm timber section on wooden frame sizes as below. Door size 3 ft * 7 ft	10.000	Nos
3	WORKSTATION & TABLE		
3.01	Providing Inspector Workstation (914mm* 610 mm *1370 mm high) with 75 mm thick modular partitions 4 inch high with raceway, softboard & Writing board above table top, with glass partitions in between the tables. Rest as prelam tiles. Table top to be 25mm thick with 1 keyboard tray and one drawer unit below. Fabric colour and shade as per departments choice.	20.00	Nos

3.01	Providing Superintendent Workstation cubicles using 75 mm thick modular partitions 4 inch high with raceway, softboard & Writing board as per drawing, Fabric colour and shade as per departments choice.	20.00	Nos
3.02	Providing necessary ply storage with laminate finish, necessary hardware and handles. Design as per drawing	6.00	Nos
4	ELECTRICAL & NETWORKING		
4.01	Electrical - General Lighting Supply and fixing of 9W/12W/15W False ceiling panel LED light fittings including wiring with PVC FRLS conduiting, switches, socket and faceplate, etc. Includes Termination of lighting wiring at existing D.B. (Make: Wires- Polycab FRLS/ RR Kabel or equivalent Switches & sockets- MK or equivalent Conduits: Aeroplast FRLS or equivalent LED Light Fitting: Panasonic/ Havells/ Philips/ Abby or equivalent	3200.000	Sq.ft
4.02	RAW power for workstations/Cabin Supply & fixing of raw power point using 1*5A switch controlled by 1 socket, UPS point using 2*5A Switches controlled by 2*5A sockets including wiring and PVC FRLS conduiting in each workstation/ cabin. Suitable Faceplate and backbox as required. Includes provision of raw power points for printers at strategic locations. All works should be carried out with necessary earthing standards.	50.000	Nos
4.03	RAW power points for AC Supply & fixing of raw power points for split AC at locations as per layout design	12.000	Nos
4.04	Networking for Workstations/ Cabin Supply & fixing of 1 Data port using CAT 6, 4-Pair UTP Cable in PVC FRLS conduits within floor/ ceiling including I.O. Keystone, freulling and crimping at user end. Suitable faceplate & backbox (Make: AMP/DLINK)	50.000	Nos
4.05	Providing necessary cabling for sensors and connectivity at required places	5.000	Nos

16. Terms and conditions: -

- (i) Minimum warranty period of the supplied items would be **one year** and the same will be effective from the date of handing over to the department.
- (ii) The firm / agency **should not be blacklisted** from any Central Government / State Government / Central and State undertakings

and / or convicted by a Court of Law. An affidavit regarding non-blacklisting of the firm should be attached as proof. In absence of proof the tender/bid will be rejected.

- (iii) In case of any dispute of any kind and in respect of whatsoever arising out of tender / contract, the decision of the Hon'ble Courts at Chennai will be final and binding.
- (iv) The department has the right to change the quantity and specifications of the items in the work order as per actual requirement, which may vary depending upon various factors.
- (v) Office of Commissioner of GST & Central Excise, Audit-II, Chennai, may, without prejudice for breach of any of the terms and conditions of the tender, 10 days after written notice of default sent to the bidder, terminate this contract in whole or in parts
 - if he fails to execute the work in full within the time period(s) specified in the tender or any extension thereof granted by , the office of Commissioner of GST & Central Excise, Audit-II, Chennai.
 - if he fails to perform any other obligation or,
 - if he, in either of the above circumstances, does not cure his failure with in a period of 30 days or longer period as specified by the office of Commissioner of GST & Central Excise, Audit-II, Chennai, after receipt of default notice from the office of Commissioner of GST & Central Excise, Audit-II, Chennai.
- (vi) The tendering firm is advised to visit the site of work i.e. 7th Floor, MHU Complex, Nandanam, Chennai-35, with prior appointment at his own cost and examine it and collect all information that he considers necessary for proper assessment of the prospective assignment. A bidder shall be deemed to have full knowledge of the site whether he inspects it or not and no extra charge consequent on any misunderstanding or otherwise shall be allowed. The bidders shall be responsible for arranging and maintaining at his own cost all materials, tools & plants, water, electricity access, facilities for workers and all other services required for executing the work unless otherwise specifically provided for in the contract documents. Submission of a bid by a bidder implies that he has read this notice and all other contract documents and has made himself aware of the scope and specifications of the work to be done and of conditions.
- (vii) All labour Employed by the Contractor shall be covered by the Workman's Compensation Act. Any death, injury or mishap to the workmen of the Contractor will entirely be the Contractor's responsibility and Commissioner of GST & Central Excise, Audit-II,

Nandanam, Chennai-600 035, shall not be liable to pay any damages for the same.

- (viii) Contractor shall take adequate/mandatory safety precautions to avoid any accident etc. at site and shall be fully responsible for any criminal & civil liabilities. All safety arrangements are to be made by contractor at his own cost.
- (ix) No labour or material rate escalation claims will be entertained from the contractor at any stage.
- (x) Removal and disposal of existing enclosures and any expense arising out of it will be fully borne by the contractor. It will not be part of the bid for this tender.
- (xi) The contractor shall be fully responsible for any damage caused to the existing building and the contractor will have to refurbish and rectify any such damage at his own risk and cost.
- (xii) Child labour strictly prohibited.
- (xiii) Only those persons who qualify for technical bid will be considered for financial bid.

17. Payments:

- (i) No advance payment will be made for any of the works stated above.
- (ii) Further payment module shall be given at the time of placing the work order with the successful bidder.

Annexure – A

(Technical bid for the supply and installation of modular work station)

1	Name of bidder:	
2	Address:	
3	Mobile no. of Bidder:	
4	PAN (enclose self attested copy of proof):	
5	GST RC (enclose self attested copy of proof)	
5	Whether blacklisted by any Central / state Government or Central / State Government under takings? If blacklisted, indicate details.(submit the affidavit about non-blacklisting in prescribed format-Annexure C)	
6	Whether convicted by any court of law? If convicted, indicate details and enclose a self attested copy of the court's order. (submit the affidavit about non-conviction in prescribed format Annexure C)	
7	Whether their annual turnover is atleast Rs.25 Lakhs in each of the last 3 financial years? (Attach supporting documents i.e. Audited Annual Account/Income Tax Return of last 3 years)	
8	Whether they have provided/ executed such Orders for two government offices/PSU/ Pvt.Firms/Companies in the last 3 years? (Attach supporting documents)	
9	Whether the bidder is a authorized dealer/ franchise firms/ Company/Manufacturer? (Supporting documents to be attached)	
10	Whether the bidder have capability to provide service after completion of work during warranty period and will be in a	

	position to offer annual maintenance contract thereafter? (List of the addresses of the branch/authorized dealers to be attached)	
--	---	--

It is certified that all the information furnished above is true and correct, that all terms and conditions stipulated in the tender document is acceptable.

Date:

Place:.....

Name and Signature of
bidder with seal

Annexure – B

(Financial bid for the supply and installation of modular work station.)

1. Name of Bidder :
2. Address:
3. Telephone / Mobile No.:
4. Rates:

SCHEDULE OF QUANTITIES			
SL.no	Description	Qty	Unit
1	Partitions		
1.01	Fixing 75mm thick wooden partitions strongly anchored/ fixed to true ceiling using aluminium hollow section as main vertical members @ 2 feet intermittent spacing and horizontal secondary members @ 4 feet intermittent spacing, fixing of 8 mm thick commercial ply on both sides finished with 1.0 mm thick approved laminate till false ceiling bottom. Laminate colour as per depts choice. (Make: Plywood- Greenply, Sharon, Century or equivalent. Laminate: Merino/ Green or equivalent)	2600.00	Sq.ft
2	Doors & Door Frames		
2.01	Providing & Fixing of 35mm flush doors finished with laminates, Including all necessary hardware like BB Hinges, Door Closer, Handle & Lock. Doors to have 100*40 mm timber section on wooden frame sizes as below. Door size 3 ft * 7 ft	10.000	Nos
3	WORKSTATION & TABLE		
3.01	Providing Inspector Workstation (914mm* 610 mm *1370 mm high) with 75 mm thick modular partitions 4 inch high with raceway, softboard & Writing board above table top, with galss partitions in between the tables. Rest as prelam tiles. Table top to be 25mm thick with 1 keyboard tray and one drawer unit below. Fabric colour and shade as per departements choice.	20.00	Nos
3.01	Providing Superintendent Workstation cubicles using 75 mm thick modular partitions 4 inch high with raceway, softboard & Writing board as per drawing, Fabric colour and shade as per departments choice.	20.00	Nos

3.02	Providing necessary ply storage with laminate finish, necessary hardware and handles. Design as per drawing	6.00	Nos
4	ELECTRICAL & NETWORKING		
4.01	Electrical - General Lighting Supply and fixing of 9W/12W/15W False ceiling panel LED light fittings including wiring with PVC FRLS conduiting, switches, socket and faceplate, etc. Includes Termination of lighting wiring at existing D.B. (Make: Wires- Polycab FRLS/ RR Kabel or equivalent Switches & sockets- MK or equivalent Conduits: Aeroplast FRLS or equivalent LED Light Fitting: Panasonic/ Havells/ Philips/ Abby or equivalent	3200.000	Sq.ft
4.02	RAW power for workstations/Cabin Supply & fixing of raw power point using 1*5A switch controlled by 1 socket, UPS point using 2*5A Switches controlled by 2*5A sockets including wiring and PVC FRLS conduiting in each workstation/ cabin. Suitable Faceplate and backbox as required. Includes provision of raw power points for printers at strategic locations. All works should be carried out with necessary earthing standards.	50.000	Nos
4.03	RAW power points for AC Supply & fixing of raw power points for split AC at locations as per layout design	12.000	Nos
4.04	Networking for Workstations/ Cabin Supply & fixing of 1 Data port using CAT 6, 4-Pair UTP Cable in PVC FRLS conduits within floor/ ceiling including I.O. Keystone, freulling and crimping at user end. Suitable faceplate & backbox (Make: AMP/DLINK)	50.000	Nos
4.05	Providing necessary cabling for sensors and connectivity at required places	5.000	Nos

Annexure – C

The Notary (Public)

Civil Court,.....

..... aged about ,
son/daughter of resident of
village..... Distt.....
do hereby solemnly affirm state as follows:

1. That I am the proprietor of M/s
2. That my Agency / firm / Central or State Government / Central or State government undertakings has been allowed to participate in the tender dated..... of the office of the Commissioner of GST & Central Excise, Audit-II, Chennai, for the supply and installation of modular work station.
3. That, I have neither been convicted nor any cognizance has been taken against by any Court of Law till date.
4. That my Agency / firm / Central or State Government / Central or State government undertakings has not been blacklisted from any Central / State Government Department and Central or State government undertakings.

The above statement is true to the best of knowledge and belief.

Witness/Deponent .

Annexure – D

**Proforma of bank guarantee for performance security
(To be stamped in accordance with stamp Act)**

Ref. No.

Date:

Bank Guarantee no.

Date:

To

The Commissioner of GST & Central Excise
Audit-II, Chennai

Dear Sir,

In consideration of the Office of the Commissioner of GST & Central Excise, Audit-II, Chennai (hereinafter referred to as the owner , which expression shall unless repugnant to the contest or meaning there of include its successors, administrators and assigns) having awarded the contract for the supply and installation of modular furniture/work station(specification) to M/swith its registered office at hereinafter referred to as contractor which expression shall unless repugnant to the context or meaning thereof, include its successors, administrators, executors and assigns), by letter of Award/work order no..... dated and the same having been acknowledged by the contractor resulting in a contract to be executed for which the contractor having agreed to provide a contract performance guarantee for the faithful performance of the entire contract amounting to Rs..... only.

We (name and address of bank) , having its head office at hereinafter referred to as the bank which expression shall, unless repugnant to the context or meaning thereof, include its successors, administrators, executors and assigns) do hereby guarantee and undertake to pay the owner, on demand any or all monies payable by the contractor to the extent of Rs..... only.

Only as aforesaid, at any time up to days/month/year) without any demur, reservation, contest, recourse or protest and / or without any reference to the contractor.

Any such demand made by the owner on the bank shall be conclusive and binding notwithstanding any difference between the owner and the contractor or any dispute pending before any court, tribunal, arbitrator or any other authority. The bank undertakes not to revoke this guarantee during its currency without previous consent of the owner and further agrees that the guarantee herein contained shall continue to be enforceable till the owner discharges this guarantee.

The owner shall have the fullest liberty without affecting in any way the liability of the bank under the guarantee from time to time to extend the time for performance or the contract by the contractor. The owner shall have the fullest liberty, without affecting this guarantee, to postpone from time to time the exercise of any powers vested in them or of any right which they might have against the contractor and to exercise the same at any time in any manner, and either to enforce or to forbear to enforce any covenants, contained or implied, in the contract between the owner and the contractor or any other course or remedy or security available to the owner. The bank shall not be released to its obligation under these presents by any exercise by the owner of its liberty with reference to the matters aforesaid or any of them or by reason of any other act of omission or commission on the part of the owner or any other indulgences shown by the owner or by any other matter or thing whatsoever which under law would, but for this provisions have the effect of relieving the bank.

The bank also agrees that the owner at its option shall be entitled to enforce this guarantee against the bank as a principal debtor, in the first instance without proceeding against the contractor and notwithstanding any security or other guarantee the owner may have in relation to the contractor s liabilities.

Notwithstanding anything contained herein above our liability under this guarantee is restricted to and it shall remain in force up to and including..... and shall be extended from time to time for such period not exceeding one year , as may be desired by M/s on whose behalf this guarantee has been given.

Dated this Day of at

Witness:

(Signature)

(Signature)

(Name)

(Name)

(Official Address)

(Official Address)

Attorney as per power of Attorney no..... date..... * *
* * * *

Annexure - E

PROPOSED PLAN FOR SUPPLY & INSTALLATION OF MODULAR OFFICE
AT SEVENTH FLOOR IN MHU COMPLEX, 692, ANNA SALAI,
NANDANAM, CHENNAI-600 035

Drawing enclosed

Proposed Layout Diagram for "Supply and Installation of Modular Workstation"
 at The Office of Commissioner of GST & Central Excise, 7th floor, Northwing,
 692, MHU complex, Anna Salai, Nandanam, Chennai-35

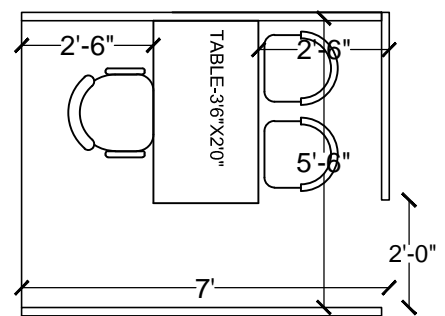
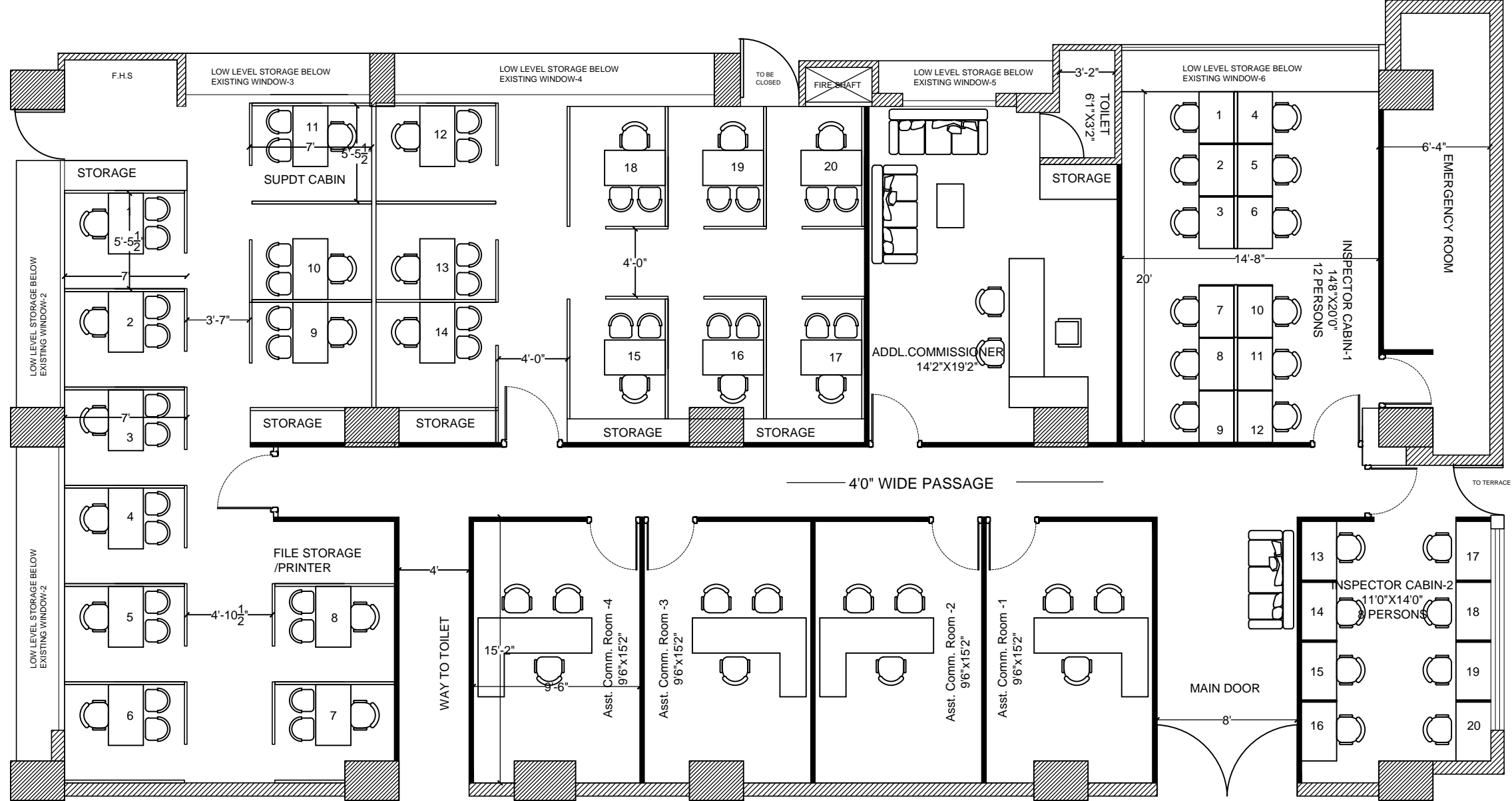
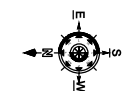

SUPTD CABIN
CUBICLE MODULE

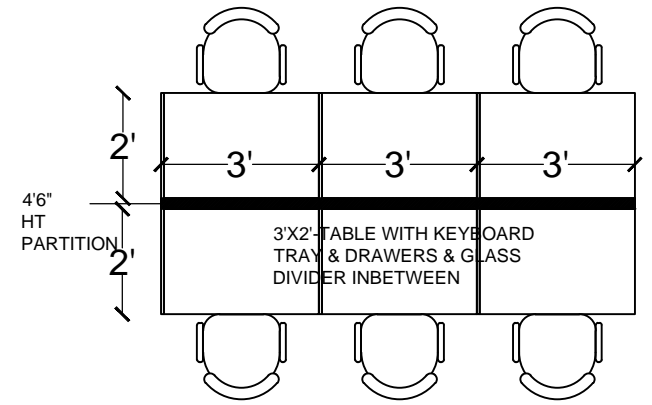

INSPECTOR CABIN
WORK STATION MODULE

[Validate](#)[Print](#)[Help](#)

Item Rate BoQ

Tender Inviting Authority: Commissioner GST Audit-II, Chennai

Name of Work: Supply & Installation of Modular Workstation at 7th Floor, GST Audit-II Commissionerate, Chennai

Contract No: 002/2017

Name of the Bidder/ Bidding Firm / Company :	
--	--

PRICE SCHEDULE

(This BOQ template must not be modified/replaced by the bidder and the same should be uploaded after filling the relevent columns, else the bidder is liable to be rejected for this tender. Bidders are allowed to enter the Bidder Name and Values only)

NUMBER #	TEXT #	NUMBER #	TEXT #	NUMBER	NUMBER #	NUMBER #	TEXT #
Sl. No.	Item Description	Quantity	Units	Estimated Rate in Rs. P	BASIC RATE In Figures To be entered by the Bidder (Inclusive of all taxes) in Rs. P	TOTAL AMOUNT inclusive of all Taxes in Rs. P	TOTAL AMOUNT In Words
1	2	4	5	6	13	53	55
1	Partitions						
1.1	Fixing 75mm thick wooden partitions strongly anchored/ fixed to true ceiling using aluminium hollow section as main vertical members @ 2 feet intermittent spacing and horizontal secondary members @ 4 feet intermittent spacing, fixing of 8 mm thick commercial ply on both sides finished with 1.0 mm thick approved laminate till false ceiling bottom. Laminate colour as per depts choice (Make: Plywood- Greenply, Sharon, Century or equivalent. Laminate: Merino/ Green or equivalent)	2600.000	Sqft	1.00		0.00	INR Zero Only
2	Doors & Door Frames						
2.1	Providing & Fixing of 35mm flush doors finished with laminates, Including all necessary hardware like BB Hinges, Door Closer, Handle & Lock. Doors to have 100*40 mm timber section on wooden frame sizes as below. Door size 3 ft * 7 ft	10.000	Nos	1.00		0.00	INR Zero Only
3	WORKSTATION & TABLE						
3.1	Providing Inspector Workstation (914mm* 610 mm *1370 mm high) with 75 mm thick modular partitions 4 inch high with raceway, softboard & Writing board above table top, with galss partitions in between the tables. Rest as prelam tiles. Table top to be 25mm thick with 1 keyboard tray and one drawer unit below. Fabric colour and shade as per departements choice.	20.000	Nos	1.00		0.00	INR Zero Only

3.2	Providing Superintendent Workstation cubicles using 75 mm thick modular partitions 4 inch high with raceway, softboard & Writing board as per drawing, Fabric colour and shade as per departements choice.	20.000	Nos	1.00		0.00	INR Zero Only
3.3	Providing necessary ply storage with laminate finish, necessary hardware and handles. Design as per drawing	3.000	Nos	1.00		0.00	INR Zero Only
4	ELECTRICAL & NETWORKING						
4.1	Electrical - General Lighting Supply and fixing of 9W/12W/15W False ceiling panel LED light fittings including wiring with PVC FRLS conduiting, switches, socket and faceplate, etc. Includes Termination of lighting wiring at existing D.B. (Make: Wires- Polycab FRLS/ RR Kabel/ Switches & sockets- MK/ / Conduits:Aeroplast FRLS LED Light Fitting: Panasonic/ Havells/ Philips/ Abby or equivalent	3200.000	Sqft	1.00		0.00	INR Zero Only
4.2	RAW power for workstations/Cabin Supply & fixing of raw power point using 1*5A switch controlled by 1 socket, UPS point using 2*5A Switches controlled by 2*5A sockets including wiring and PVC FRLS conduiting in each workstation/ cabin. Suitable Faceplate and backbox as required. Includes provision of raw power points for printers at strategic locations. All works should be carried out with necessary earthing standards.	50.000	Nos	1.00		0.00	INR Zero Only
4.3	RAW power points for AC Supply & fixing of raw power points for split AC at locations as per layout design	12.000	Nos	1.00		0.00	INR Zero Only
4.4	Networking for Workstations/ Cabin Supply & fixing of 1 Data port using CAT 6, 4-Pair UTP Cable in PVC FRLS conduits within floor/ ceiling including I.O. Keystone, freulling and crimping at user end. Suitable faceplate & backbox (Makes: AMP/DLINK	50.000	Nos	1.000		0.00	INR Zero Only
4.5	Providing necessary cabling for sensors and connectivity at required places	5.000	Nos	1.000		0.00	INR Zero Only
Total in Figures						0.00	INR Zero Only
Quoted Rate in Words		INR Zero Only					