

Phone: 044-24323800



Fax No: 044-24323900

भारत सरकार/ GOVT. OF INDIA  
वित्त मंत्रालय, राजस्व विभाग  
MINISTRY OF FINANCE, DEPARTMENT OF REVENUE  
केंद्रीय वस्तुओं, सेवा कर और केंद्रीय उत्पाद शुल्क आयुक्त का कार्यालय - लेखा परीक्षा-II  
OFFICE OF THE COMMISSIONER OF GOODS AND SERVICE TAX & CENTRAL EXCISE  
AUDIT II COMMISSIONERATE  
692, एम. एच. यू. कॉम्प्लेक्स, नन्दनम, चेन्नै - 600035  
692, M. H. U. COMPLEX, NANDANAM, CHENNAI - 600 035

---

C. No. I/22/7/2018-GST-Audit-II

Dated: 27/09/2018

**E-TENDER NOTICE – 005/2018**

Sub:- Notice for inviting E-Tender for **Supply and Installation of modular workstation & Extension of Conference Hall in the Office of the Commissioner of GST & Central Excise, Audit-II, at 6th Floor South Wing and 4thFloor- North Wing, Nandanam, Chennai-600035-Reg.**

\*\*\*\*\*

Online tenders are invited from reputed firm/Company/Manufacturer for supply and installation of modular workstation in the **Office of the Commissioner of GST & Central Excise, Audit-II, at**

- a) **6th Floor South Wing – Refer-Annexure E1**  
Modular Workstation
- b) **4thFloor- North Wing, Nandanam, Chennai-600035-Annexure E2**  
Modular Workstation & Extension of Conference Hall

2. Last date for uploading the tender documents by bidders duly completed in all respect is at **13:00 on 20-10-2018.**

3. The lump sum amount to be quoted for the entire work by the tenderers shall include all taxes as applicable at the time of awarding of contract and during the execution of work till completion.

4. The Commissioner of GST & Central Excise, Audit-II, Chennai-35, reserves the right to reject or accept any application/tender without assigning any reason.

5. Any inquiries by the tenderer may be obtained from the undersigned on any working day from 1100 hours to 1700 hours between 28-09-2018 to 17-10-2018 This tender notice is also available on the official website at <https://eprocure.gov.in/eprocure/app> **Tender Reference No: 2018\_DREV\_389043\_1**, <http://centralexcisechennai.gov.in/> and <http://www.cbec.gov.in/htdocs-cbec/tender/tenders-idx>. For any further queries, firms may also contact 044-24327210.

**-Sd/-**  
**(SUBHA CHANDRAN)**  
**Assistant Commissioner (Admin)**  
**GST -Audit-II, Chennai-35.**

Note : The complete tender documents viz. Technical bid and Financial bid along with scope of work, terms and conditions and tender process can be accessed & downloaded from

Portal <https://eprocure.gov.in/eprocure/app>

**Tender Reference No: 2018\_DREV\_389043\_1**

Please check regularly the website for any changes/modification/amendment in the Tender Enquiry. This Tender Enquiry (TE) is being issued with no financial commitment and department reserves the right to change or vary any part thereof at any stage. The department also reserves the right to withdraw the tender enquiry, should it become necessary at any stage.



भारत सरकार/ GOVT. OF INDIA  
वित्त मंत्रालय, राजस्व विभाग  
MINISTRY OF FINANCE, DEPARTMENT OF REVENUE  
केंद्रीय वस्तुओं, सेवा कर और केंद्रीय उत्पाद शुल्क आयुक्त का कार्यालय - लेखा परीक्षा-II  
OFFICE OF THE COMMISSIONER OF GOODS AND SERVICE TAX & CENTRAL EXCISE  
AUDIT II COMMISSIONERATE  
692, एम. एच. यू. कॉम्प्लेक्स, नन्दनम, चेन्नै - 600035  
692, M. H. U. COMPLEX, NANDANAM, CHENNAI - 600 035

C. No. I/22/7/2018-GST-Audit-II

Dated: 27/9/2018

**E.Tender No.005/2018**

**Tender Documents**

Online tenders are invited from reputed firm/Company/Manufacturer for **Supply and Installation of modular workstation & Extension of Conference Hall in the Office of the Commissioner of GST & Central Excise, Audit-II, at**

- a) **6<sup>th</sup> Floor South Wing & (Area around appr. (6200 Sq.ft)**
- b) **4<sup>th</sup> Floor- North Wing (Area around appr. 5000 Sq.ft)**

**1. Tender Process and uploading of Tender documents: -**

The bid / tender will consist of two parts – Technical bid and Financial bid. The bid of all parties whose rates quoted by them finds mention in their Technical Bid shall be rejected forthwith. All information sought under terms and conditions and other information to be supplied is to be given in Technical Bid while the price quoted by them will be mentioned only in the Financial Bid.

- (i) The offers / bids received incomplete and / or filed after the due date and time shall be summarily rejected.
- (ii) The Technical Bids shall be opened on **22/10/2018 at 14:00 Hrs** in the presence of bidder or their authorized representative with authority letter, if they appear.
- (iii) The financial bids of only those parties shall be opened whose Technical Bids are found to be eligible.
- (iv) The department reserves the right to accept or reject any or all tenders without assigning any reason. In case of any dispute of any kind and in respect of whatsoever, the decision of the Commissioner of GST & Central Excise, Audit-II, 6<sup>th</sup> Floor, Nandanam, Chennai-600035, will be final and binding.

2. **Authenticity of the tender document:** -  
Every page of tender document along with enclosures must be signed by the bidder.

3. **Tender Document**

The tender documents containing terms and conditions alongwith prescribed proforma / format for furnishing required information / details can be obtained from the Assistant Commissioner (Admin), GST-Audit-II, No.692, Anna Salai, 6th Floor, MHU Complex, Nandanam, Chennai-600035, on any working day from 24/09/2018 to 17/10/2018 from 11:00 AM to 5:00 PM. Alternatively the tender can be downloaded from the portal <https://eprocure.gov.in/eprocure/app> and <http://www.cbec.gov.in/htdocs-cbec/tender/tenders-idx>

4. **Earnest Money Deposit [EMD]:**

- (i) Tender documents must be accompanied with non-interest bearing Earnest Money of **Rs.75,000 /- (Rs. Seventy Five Thousand only)** in form of Demand Draft in favour of the Commissioner of GST & Central Excise, Audit-II, Chennai payable at Chennai, failing which tender will be summarily rejected.
- (ii) Cheques will not be accepted.
- (iii) No earnest money deposit will be accepted after the due date and time of submission of tender document.
- (iv) Earnest money deposited with other Tender will not be adjustable with this Tender.
- (v) No bank commission or interest will be paid on the earnest money deposit.
- (vi) If a bidder withdraws its offer after opening of Technical Bid or Financial Bid before award of tender to other valid tenderer, the earnest money deposited by them will be forfeited.
- (vii) If a successful bidder fails to deposit requisite amount towards the Performance Security within specified time as per intimation / request of Commissioner of GST & Central Excise, Audit-II, Chennai, the earnest money deposited will be forfeited.
- (viii) Central / State Government and Central / State Government Undertakings are exempted from deposit of Earnest Money.

5. **Performance Security:** -

The successful tenderer will be wholly and solely responsible for any damage/levy/claim and will be liable to pay the said damage/levy/claim. In this context, the successful bidder will deposit **Rs. 75,000/- (Rs. Seventy five thousand only)** as performance security which is non-interest bearing in the shape of Bank Draft / Bank Guarantee issued by a Nationalized Bank only drawn in favour of the Commissioner of GST & Central Excise, Audit-II, Chennai.

**6. Refund of Earnest Money Deposit & Performance Security: -**

- (i) Earnest money deposited by the unsuccessful bidder will be refunded to bidder at the earliest after finalization of the tender. Earnest money will be refunded to the successful bidder on receipt of Performance Security.
- (ii) Further, the performance security will be refunded/ returned to the successful bidder after successful execution of the work.
- (iii) The Performance Security will be forfeited in case of unsatisfactory performance of the successful bidder. The decision of the Commissioner of GST & Central Excise, Audit-II, Chennai on this account will be final and binding on successful bidder.

**7. Rates: -**

- (i) Rate/bid/offer must be without any condition, assumption, qualification, reservation or variation. Rate/ bid/offer must be mentioned in prescribed proforma in figures and in words in respect of each item separately. In case of any discrepancy, rates quoted in words will prevail. Conditional tender offer or offer at variance from prescribed specification would be ineligible to compete for the tender. Prices and price components shall be firm and shall not be subject to any price variation or adjustment on account of any price escalations throughout the execution of the contract.
- (ii) The bidder shall quote their rate inclusive of all taxes, installation and transport charges.
- (iii) The rates have to be shown separately in the financial bid (Annexure B) i.e in BOQ Excel sheet.

**8. Subletting of Contract: -**

The successful bidder shall not be allowed to sublet / subcontract the contract to any other contractor.

**9. Completion Period :-**

- (i) Contract has to completed within a period of 90 days from date of supply order/Award of work.
- (ii) Liquidated damage (LD) will be charged @ of 2.50% per completed week or part thereof for delay subject to maximum of 10% of the value of work order.

**10. Prescribed format / proforma: -**

- (i) **Annexure – A** and **Annexure – B** are to be duly filled by the bidder in respect of each item.
- (ii) An affidavit in prescribed proforma i.e. **Annexure – C** regarding non-blacklisting or non-convicting by any court of law is to be duly submitted.

- (iii) The successful bidder has to submit a Demand Draft or a bank guarantee towards performance security in the prescribed proforma i.e. **Annexure – D**.

**11. Documents required to be attached with technical bid:**

- (i) Complete technical specifications along with brochure / photograph/ coloured picture if any.
- (ii) A Copy of Terms & conditions **duly signed** by the bidder (including warranty and after sales service except price schedule).
- (iii) Demand Draft / Bank Guarantee of Rs.75,000/- (Rs. Seventy five thousand only) in favour of the Commissioner of GST & Central Excise, Audit-II Chennai payable at Chennai as Earnest Money Deposit.
- (iv) GST Registration Certificate
- (v) All other supporting documents as required in the tender shall be attached.
- (vi) Signed declaration as given on **Annexure –C** of the bid document.
- (vii) Experience certificate (for details of similar contracts handled by the tendering company /firm/agency for government departments/PSUs /Banks/other Pvt.Firms/Companies during the last three years. (List should be enclosed in technical bid).
- (viii) Balance sheet for the last 3 financial years.

**12. Eligibility criteria for bidder: -**

- (i) Only those firms/Company/ Manufacturers will be eligible to tender their bids whose annual turnover is atleast Rs.30 Lakhs or above in each of the last three financial years.
- (ii) Only those firms who have Experience of having successfully completed similar works during last 7 years ending last day of month ending August' 2018 should be either of the following: -
  - a. Three similar completed works costing not less than the amount equal to Rs.30 Lakhs. Or
  - b. Two similar completed works costing not less than the amount equal to Rs.30 Lakhs. Or
  - c. One similar completed work costing not less than the amount equal to Rs.60 Lakhs.
- (iii)** The firms /Company/ Manufacturers should have executed such orders in at least for two government offices /PSU / Pvt.Firms/ Companies in the last 3 years. The authorized dealer/ franchise / distributor may submit bids on behalf of the firms/ Company/Manufacturer along with valid authorization letter issued by the firms/ Company/Manufacturers to the bidder for this particular tender, to do so. Preference would be given to manufacturers **registered with National Small Industries**

**Corporation (NSIC), Ministry of Micro Small and Medium Enterprises (MSME). [supporting documents to be attached]**

- (iv) The bidder should have capability to provide after sales service during warranty period and should be in a position to offer annual maintenance contract thereafter. The bidder should have registered branch office/Dealers network in Chennai. List of the addresses of the branch/ Authorized dealers to be attached.
- (v) Preference will be given to bidders who have successfully completed similar works in Central/ State Government organisations.

**13. Validity of the offer / bid: -**

The offer / bid of the bidder will be valid for at least for 3 months from the date of opening of Technical bid.

**14. Details of tendered items: -**

The supply and installation of modular workstation/renovation is to be carried out as per plan given in drawings annexed as Annexure E of this tender document. Detailed work items is attached as Annexure-B

**15. Terms and conditions: -**

- (i) Minimum warranty period of the supplied items would be **one year** and the same will be effective from the date of handing over to the department.
- (ii) The firm / agency **should not be blacklisted** from any Central Government / State Government / Central and State undertakings and / or convicted by a Court of Law. An affidavit regarding non-blacklisting of the firm should be attached as proof. In absence of proof the tender/bid will be rejected.
- (iii) In case of any dispute of any kind and in respect of whatsoever arising out of tender / contract, the decision of the Hon'ble Courts at Chennai will be final and binding.
- (iv) The department has the right to change the quantity and specifications of the items in the work order as per actual requirement, which may vary depending upon various factors.
- (v) Office of Commissioner of GST & Central Excise, Audit-II, Chennai, may, without prejudice for breach of any of the terms and conditions of the tender, 10 days after written notice of default sent to the bidder, terminate this contract in whole or in parts
  - if he fails to execute the work in full within the time period(s) specified in the tender or any extension thereof granted by ,

the Office of Commissioner of GST & Central Excise, Audit-II, Chennai.

- if he fails to perform / execute the work order conditions; or,
  - if he, in either of the above circumstances, does not cure his failure within a period of 30 days or longer period as specified by the Office of Commissioner of GST & Central Excise, Audit-II, Chennai, after receipt of default notice from the Office of Commissioner of GST & Central Excise, Audit-II, Chennai.
- (vi) The tendering firm **is advised to visit the site of work i.e. 6<sup>th</sup> Floor, - South Wing, MHU Complex, Nandanam, Chennai-35, with prior appointment at his own cost and examine it and collect all information that he considers necessary for proper assessment of the prospective assignment. Also, the tendering firms are requested to have a thorough inspection of the existing 4<sup>th</sup> floor Conference hall, which is proposed to be extended,**
- (vii) **A bidder shall be deemed to have full knowledge of the site whether he inspects it or not and no extra charge consequent on any misunderstanding or otherwise shall be allowed.** The bidders shall be responsible for arranging and maintaining at his own cost all materials, tools & plants, water, electricity access, facilities for workers and all other services required for executing the work unless otherwise specifically provided for in the contract documents. Submission of a bid by a bidder implies that he has read this notice and all other contract documents and has made himself aware of the scope and specifications of the work to be done and of conditions.
- (viii) All labour Employed by the Contractor shall be covered by the Workman's Compensation Act. Any death, injury or mishap to the workmen of the Contractor will entirely be the Contractor's responsibility and Commissioner of GST & Central Excise, Audit-II, Nandanam, Chennai-600 035, shall not be liable to pay any damages for the same.
- (ix) Contractor shall take adequate/mandatory safety precautions to avoid any accident etc. at site and shall be fully responsible for any criminal & civil liabilities. All safety arrangements are to be made by contractor at his own cost.
- (x) No labour or material rate escalation claims will be entertained from the contractor at any stage.
- (xi) Removal and disposal of existing enclosures and any expense arising out of it will be fully borne by the contractor. It will not be part of the bid for this tender.



- (xii) The contractor shall be fully responsible for any damage caused to the existing building and the contractor will have to refurbish and rectify any such damage at his own risk and cost.
- (xiii) Child labour strictly prohibited.
- (xiv) Only those persons who qualify for technical bid will be considered for financial bid.

**16. Payments:**

- (i) No advance payment will be made for any of the works stated above.
- (ii) Further payment module shall be given at the time of placing the work order with the successful bidder.

**Annexure – A**

**(Technical bid for the supply and installation of modular work station-South Wing -6<sup>th</sup> floor and extension of conference hall & modular work station at 4<sup>th</sup> floors of MHU Complex, Nandanam, Chennai-600035)**

1	Name of bidder:	
2	Address:	
3	Mobile no. of Bidder:	
4	PAN (enclose self attested copy of proof):	
5	GST RC (enclose self attested copy of proof)	
5	Whether blacklisted by any Central / state Government or Central / State Government under takings? If blacklisted, indicate details.(submit the affidavit about non-blacklisting in prescribed format-Annexure C)	
6	Whether convicted by any court of law? If convicted, indicate details and enclose a self attested copy of the court's order. (submit the affidavit about non-conviction in prescribed format Annexure C)	
7	Whether their annual turnover is atleast Rs.25 Lakhs in each of the last 3 financial years? (Attach supporting documents i.e. Audited Annual Account/Income Tax Return of last 3 years)	
8	Whether they have provided/ executed such Orders for two government offices/PSU/ Pvt.Firms/Companies in the last 3 years? (Attach supporting documents)	
9	Whether the bidder is a authorized dealer/ franchise firms/ Company/Manufacturer? (Supporting documents to be attached)	

10	Whether the bidder have capability to provide service after completion of work during warranty period and will be in a position to offer annual maintenance contract thereafter? (List of the addresses of the branch/authorized dealers to be attached)	
----	--	--

It is certified that all the information furnished above is true and correct, that all terms and conditions stipulated in the tender document is acceptable.

Date: .....

Place:.....

Name and Signature of bidder with seal

**Annexure – B****(Financial bid for the supply and installation of modular work station.)**

1. Name of Bidder :

2. Address:

3. Telephone / Mobile No.:

<b>SCHEDULE OF QUANTITIES</b>			
<b>SL.no</b>	<b>Description</b>	<b>Qty</b>	<b>Unit</b>
<b>1</b>	<b>Partitions 4th Floor- North Wing</b>		
1.1	Fixing 75mm thick wooden partitions strongly anchored/ fixed to true ceiling using heavy aluminium hollow section of dimensions 50mm x 25mm with aluminium thickness of 3mm as main vertical members @ 2 feet intermittent spacing and horizontal secondary members @ 2 feet intermittent spacing, fixing of 12 mm thick marine ply (BWR Grade) on both sides finished with 1.0 mm thick laminate of approved shade on both sides till false ceiling. (Make: Plywood- Kitply / Greenply / Sharon / Century or equivalent. (BWR/Marine Grade) Laminate: Merino/ Green or equivalent) <b>Refer Drawing 'A'</b>	3100	Sqft
1.2	Providing half height partitions made of heavy aluminium sections of dimension 50mm x 25mm with aluminium thickness of 3mm Frame work grid should be main vertical members @ 2 feet intermittent spacing and horizontal secondary members @ 2 feet intermittent spacing, fixing of 12 mm thick marine ply (BWR Grade) on both sides finished with 1.0 mm thick laminate of approved shade on both sides up to 4 feet. Above that 1feet of 12mm SAINT GOBAIN clear glass with etching should be fixed with good quality wooden moulding. <b>Refer Drawing 'B'</b>	1650	Sqft
1.3	Providing and fixing wall panelling at open areas in 4 <sup>th</sup> floor using heavy aluminium hollow section of dimensions 50mm x 25mm with aluminium thickness of 3mm as main vertical members @ 2 feet intermittent spacing and horizontal secondary members @ 2 feet intermittent spacing, fixing of 12 mm thick marine ply (BWR Grade) on one sides finished with 1.0 mm thick laminate of approved shade on one side till false ceiling.	100	Sqft
<b>2</b>	<b>Doors &amp; Door Frames 4th Floor</b>		

2.1	Providing & Fixing of 35mm thick flush doors finished with laminates on both sides, Including all necessary hardware like Hinges, Door Closer, Handle & Lock, Door Stopper fixed on wooden frame sizes as below. Door size 3 ft x 7 ft. Wooden frame to be made of well seasoned good quality Hardwood.	13.00	Nos
2.2	Providing & Fixing of 35mm thick flush doors finished with laminates, Including all necessary hardware like BB Hinges, Door Closer, Handle & Lock Door Stopper fixed on wooden frame sizes as below. Door size 5 ft x 7 ft. Wooden frame to be made of well seasoned good quality Hardwood.	2.000	Nos
<b>3</b>	<b>TABLES 4th Floor-North Wing</b>		
3.1	Supply of Table for <b>Inspector</b> – of Size <b>4’0” x 2’0”</b> and should be made from <b>19mm marine ply (BWR Grade)</b> finished with 1mm laminate on both the sides and suitable hardware and locking arrangement with pullout key board tray. <b>Table Top should be of 40 mm solid thick marine ply (BWR Grade)</b> finished with laminate on both sides. <b>Refer – Drawing C.</b>	20.000	Nos
3.2	Supply of Table for <b>Superintendent</b> – of Size <b>5’0” x 2’6”</b> and should be made from <b>19mm marine ply (BWR Grade)</b> finished with 1mm laminate on both the sides and suitable hardware and locking arrangement. Table Top should be of <b>40 mm solid thick marine ply (BWR Grade)</b> finished with laminate on both sides. <b>Refer – Drawing D.</b>	20.000	Nos
3.3	Supply of <b>Computer Table</b> for <b>Superintendent</b> – of Size <b>3’0”x1’6”</b> and should be made from <b>19mm marine ply (BWR Grade)</b> with finished 1mm laminate on both the sides and suitable hardware and locking arrangement with pullout key board tray. Table Top should be made of <b>40 mm solid thick marine ply (BWR Grade)</b> finished with laminate on both sides. <b>Refer – Drawing E.</b>	20.00	Nos
3.4	Table for <b>Assistant Commissioner</b> – of Size <b>6’0” x 3’0”</b> and should be made from <b>19mm marine ply (BWR Grade)</b> finished with 1mm laminate on both the sides and suitable hardware and locking arrangement. Table Top should be of <b>40 mm solid thick marine ply (BWR Grade)</b> finished with 1mm laminate on both the sides <b>Refer – Drawing F.</b>	3.00	Nos
3.5	Supply of <b>Computer Table</b> for <b>Assistant Commissioner</b> – of Size <b>4’0” x 1’6”</b> and should be made from <b>19mm marine ply (BWR Grade)</b> finished with 1mm laminate on both the sides and suitable hardware and locking arrangement with pullout key board tray. Table Top should be of <b>40 mm solid thick marine ply (BWR Grade)</b> finished with 1mm laminate on both the sides. <b>Refer – Drawing G.</b>	3.00	Nos
<b>4</b>	<b>ELECTRICAL – 4th Floor North Wing</b>		
4.1	<b>Electrical Light fitting</b> Supply and fixing of 36W 600mm*600mm False ceiling panel	65	Nos

	<p>LED light fittings including wiring of 2.5 Sq.mm 2 run and 1.5 Sq.mm of 1 run with PVC FRLS conduiting, switches, socket and faceplate, etc. Includes Termination of lighting wiring at existing D.B. (Make: <b>Wires-</b> Polycab FRLS/ Havells FRLS/ RR Kabel FRLS of ISI standard or Equivalent <b>Switches &amp; sockets-</b> MK/ Anchor Roma/Havells or Equivalent <b>Conduits:</b> Aeroplast FRLS or Equivalent <b>LED Light Fitting:</b> Wipro/ Panasonic/ Havells/ Philips/ Abby or equivalent</p>		
4.2	<p><b>RAW / UPS power points for AC's / Supdts/ Inspectors</b> Supply &amp; fixing of raw power point using 2.5 Sq.mm of 2 run and 1.5 Sq.mm of 1 run connected to 1*5A switch controlled by 2*5A, 3pin socket, UPS point using 1*5A Switches controlled by 1*5A sockets. All works should be carried out with necessary earthing standards. Suitable Faceplate and backbox as required. <b>Make: Switches &amp; sockets-</b> MK/ Anchor Roma/Havells or Equivalent</p>	50	Nos
4.3	<p><b>RAW power points for 15 amps</b> Supply &amp; fixing of raw power point using 4.0 Sq.mm of 2 run and 2.5 Sq.mm of 1 run connected with 15 amps socket and switch. All works should be carried out with necessary earthing standards. Suitable Faceplate and backbox as required. <b>Make: Switches &amp; sockets-</b> MK/ Anchor Roma/Havells or Equivalent.</p>	5.000	Nos
4.4	<p><b>RAW power points for AC</b> Supply &amp; fixing of raw power points for Split/Casette AC at various locations in the layout Specification: Raw power point using 4.0 Sq.mm of 2 run and 2.5 Sq.mm of 1 run connected with 15 amps socket and Mini MCB switch.</p>	7.000	Nos
<b>5</b>	<b>Networking for AC/Supdts/Inspector – 4<sup>th</sup> Floor North wing</b>		
5.1	<p><b>Networking Points</b> Supply &amp; fixing of 2 data port (one for internet &amp; one for Intranet) having 2 socket using CAT 6 cable, 4-Pair UTP Cable in PVC FRLS conduits within floor/ ceiling including I.O. Keystone, feruling and crimping at user end. Suitable faceplate &amp; backbox ( Makes: AMP/DLINK)</p>	50.00	Nos
5.2	<p><b>Supply and fixing of 2 pair telephone cable of ISI standard for Supdt and Assistant Commissioner</b> <b>Having one 2 way telephone socket fixed in a plate and</b> Suitable faceplate &amp; backbox</p>	25	Nos.
<b>6</b>	<b>Flooring 4<sup>th</sup> Floor – North Wing</b>		

**E.Tender No.005/2018**

6.1	Laying of <b>2'0" x 2'0"</b> Vitrified tiles after chipping of existing mosaic tiles, including clearing and disposal of debris, Tiles design as per departments choice Make: ( Somany, Kajaria or Equivalent) basic rate of tiles Rs.45 per Sqft.	3600.000	sqft
6.2	Skirting of <b>4"</b> for the above tile work (6.1) Make: ( Somany, Kajaria or Equivalent) basic rate of tiles Rs.45 per Sqft.	250	Rft
<b>7</b>	<b>False Ceiling - 4th Floor – North Wing</b>		
7.1	Supplying and Erecting Saint Gobain, Gyproc gypboard false ceiling at <b>9'0"</b> height. framework of G.I. Section (of medium thickness) of spacing 4'0"x2'0" above which 12.5mm gyproc board shall be fixed. Rate shall include cut-outs for light fittings, speakers and etc.	3600.00	sqft
<b>8</b>	<b>Storage Units for 4th Floor-North Wing</b>		
8.1	Supply of Storage units of size <b>5'0" x 3'0" x 1'6"</b> made of 19mm marine ply (BWR Grade) finished with 1mm laminate on both side with suitable hardware and locking arrangement having equal shutters. Top should of <b>40 mm solid</b> marine ply (BWR Grade) finished with 1mm laminate on both side- <b>Refer Drawing H</b>	15	Nos
<b>9</b>	<b>Partitions 6th Floor – South Wing</b>		
9.1	Fixing 75mm thick wooden partitions strongly anchored/ fixed to true ceiling using heavy aluminium hollow section of dimensions 50mm x 25mm with aluminium thickness of 3mm as main vertical members @ 2 feet intermittent spacing and horizontal secondary members @ 2 feet intermittent spacing, fixing of 12 mm thick marine ply (BWR Grade) on both sides finished with 1.0 mm thick laminate of approved shade on both sides till false ceiling. (Make: Plywood- Kitply / Greenply / Sharon / Century or equivalent. (BWR/Marine Grade) Laminate: Merino/ Green or equivalent) <b>Refer Drawing 'A'</b>	3000	Nos
9.2	Providing half height partitions made of heavy aluminium sections of dimension 50mm x 25mm with aluminium thickness of 3mm. Frame work grid should be main vertical members @ 2 feet intermittent spacing and horizontal secondary members @ 2 feet intermittent spacing, fixing of 12 mm thick marine ply (BWR Grade) on both sides finished with 1.0 mm thick laminate of approved shade on both sides up to 4 feet. Above that 1feet of 12mm SAINT GOBAIN clear glass with etching should be fixed with good quality wooden moulding. <b>Refer Drawing 'B'</b>	2800	
<b>10</b>	<b>Doors &amp; Door Frames 6th Floor – South Wing</b>		

**E.Tender No.005/2018**

10.1	Providing & Fixing of 35mm thick flush doors finished with laminates on both sides, Including all necessary hardware like Hinges, Door Closer, Handle & Lock, Door Stopper fixed on wooden frame sizes as below. Door size 3 ft x 7 ft. Wooden frame to be made of well seasoned good quality Hardwood.	14.00	Nos
10.2	Providing & Fixing of 35mm thick flush doors finished with laminates, Including all necessary hardware like Hinges, Door Closer, Handle & Lock Door Stopper fixed on wooden frame sizes as below. Door size 5 ft x 7 ft. Wooden frame to be made of well seasoned good quality Hardwood.	3.000	Nos
<b>11</b>	<b>TABLE 6th Floor – South Wing</b>		
11.1	Supply of Table for <b>Inspector</b> – of Size <b>4’0” x 2’0”</b> and should be made from 19mm marine ply (BWR Grade) finished with 1mm laminate on both the sides and suitable hardware and locking arrangement with pullout key board tray. Table Top should be of 40 mm solid thick marine ply finished with laminate on both sides. <b>Refer – Drawing C.</b>	30	Nos
11.2	Supply of Table for <b>Superintendent</b> – of Size <b>5’0” x 2’6”</b> and should be made from 19mm marine ply (BWR Grade) finished with 1mm laminate on both the sides and suitable hardware and locking arrangement. Table Top should be of 40 mm solid thick marine ply finished with laminate on both sides. <b>Refer – Drawing D.</b>	30	Nos
11.3	Supply of <b>Computer Table</b> for <b>Superintendent</b> – of Size <b>3’0”x1’6”</b> and should be made from 19mm marine ply (BWR Grade) with finished 1mm laminate on both the sides and suitable hardware and locking arrangement with pullout key board tray. Table Top should be made of 40 mm solid thick marine ply finished with laminate on both sides. <b>Refer – Drawing E.</b>	30	Nos
11.4	Table for <b>Assistant Commissioner</b> – of Size <b>6’0” x 3’0”</b> and should be made from 19mm marine ply (BWR Grade) finished with 1mm laminate on both the sides and suitable hardware and locking arrangement. Table Top should be of 40 mm solid thick marine ply (BWR Grade) finished with 1mm laminate on both the sides <b>Refer – Drawing F.</b>	4.00	Nos
11.5	Supply of <b>Computer Table</b> for <b>Assistant Commissioner</b> – of Size <b>4’0” x 1’6”</b> and should be made from 19mm marine ply (BWR Grade) finished with 1mm laminate on both the sides and suitable hardware and locking arrangement with pullout key board tray. Table Top should be of 40 mm solid thick marine ply (BWR Grade) finished with 1mm laminate on both the sides. <b>Refer – Drawing G.</b>	4.00	Nos
<b>12</b>	<b>ELECTRICAL - 6th Floor – South Wing</b>		



12.1	<p><b>Electrical Light fitting</b>  Supply and fixing of 36W 600mm*600mm False ceiling panel LED light fittings including wiring of 2.5 Sq.mm 2 run and 1.5 Sq.mm of 1 run with PVC FRLS conduiting, switches, socket and faceplate, etc. Includes Termination of lighting wiring at existing D.B.  (Make:  <b>Wires-</b> Polycab FRLS/ Havells FRLS/ RR Kabel FRLS of ISI standard or Equivalent  <b>Switches &amp; sockets-</b> MK/ Anchor Roma/Havells or Equivalent  <b>Conduits:</b> Aeroplast FRLS or Equivalent  <b>LED Light Fitting:</b> Wipro/ Panasonic/ Havells/ Philips/ Abby or equivalent</p>	70	No.s
12.2	<p><b>RAW / UPS power points for AC's / Supdts/ Inspectors</b>  Supply &amp; fixing of raw power point using 2.5 Sq.mm of 2 run and 1.5 Sq.mm of 1 run connected to 1*5A switch controlled by 2*5A, 3pin socket, UPS point using 1*5A Switches controlled by 1*5A sockets. All works should be carried out with necessary earthing standards. Suitable Faceplate and backbox as required.  <b>Make: Switches &amp; sockets-</b> MK/ Anchor Roma/Havells or Equivalent</p>	70	Nos
12.3	<p><b>RAW power points for 15 amps</b>  Supply &amp; fixing of raw power point using 4.0 Sq.mm of 2 run and 2.5 Sq.mm of 1 run connected with 15 amps socket and switch. All works should be carried out with necessary earthing standards. Suitable Faceplate and backbox as required.  <b>Make: Switches &amp; sockets-</b> MK/ Anchor Roma/Havells or Equivalent.</p>	5.000	Nos
12.4	<p><b>RAW power points for AC</b>  Supply &amp; fixing of raw power points for Split AC at various locations in the layout  Specification: Raw power point using 4.0 Sq.mm of 2 run and 2.5 Sq.mm of 1 run connected with 15 amps socket and Mini MCB switch.</p>	10.000	Nos
<b>13</b>	<b>Networking – 6<sup>th</sup> Floor South Wing</b>		
13.1	<p><b>Networking for AC/Supdts/Inspector</b>  Supply &amp; fixing of 2 data port (one for internet &amp; one for Intranet) having 2 socket using CAT 6 cable, 4-Pair UTP Cable in PVC FRLS conduits within floor/ ceiling including I.O. Keystone, feruling and crimping at user end. Suitable faceplate &amp; backbox (Makes: AMP/DLINK)</p>	70.00	Nos.
13.2	<p><b>Supply and fixing of 2 pair telephone cable of ISI standard for Supdt and Assistant Commissioner</b>  <b>Having one 2 way telephone socket fixed in a plate and</b>  Suitable faceplate &amp; backbox</p>	35.00	Nos.
<b>14</b>	<b>Flooring - 6<sup>th</sup> Floor – South Wing</b>		

**E.Tender No.005/2018**

14.1	Laying of <b>2'0" x 2'0"</b> Vitrified tiles after chipping of existing mosaic tiles, including clearing and disposal of debris, Tiles design as per departments choice Make: ( Somany, Kajaria or Equivalent) basic rate of tiles Rs.45 per Sqft.	6200.00	Sq.ft
14.2	Skirting of <b>4"</b> for the above tile work (14.1) Make: ( Somany, Kajaria or Equivalent) basic rate of tiles Rs.45 per Sqft.	370	Rft
<b>15</b>	<b>False Ceiling - 6<sup>th</sup> Floor - South Wing</b>		
15.1	Supplying and Erecting Saint Gobain, Gyproc gypboard false ceiling at <b>9'0"</b> height. framework of G.I. Section (of medium thickness) of spacing 4'0"x2'0" above which 12.5mm gyproc board shall be fixed. Rate shall include cut-outs for light fittings, speakers and etc.	5000.00	sqft
<b>16</b>	<b>STORAGE UNITS</b>		
16.1	Storage units of size 5 x 3 x 1.5 made of 19mm kit marine ply with 1mm laminate on both side with suitable hardware and locking arrangement having 2 equal shutters. Top should of 40 mm solid marine ply with 1mm laminate on both side- <b>Refer Drawing H</b>	30	Nos
	<b>CONFERENCE HALL @ 4<sup>th</sup> Floor</b>		
<b>17</b>	<b>Wooden Wall Panelling 4th Floor Conference Hall</b>		
17.1	Providing and fixing wall panelling to Conference Hall using heavy aluminium hollow section of dimensions 50mm x 25mm with aluminium thickness of 3mm as main vertical members @ 2 feet intermittent spacing and horizontal secondary members @ 2 feet intermittent spacing, fixing of 12 mm thick marine ply (BWR Grade) on one sides finished with 1.0 mm thick laminate of approved shade on one side till false ceiling.	1200	Sqft
<b>18</b>	<b>Wooden Flooring for Conference Room - 4th Floor - North Wing</b>		
18.1	Laying of wooden flooring of 8 mm thickness of AC3 quality of size 1202 mm x 192 mm planks waterproofs interlocking type fixed on one layer of 1mm pvc sheet with one layer of 4 mm PU foam 40 mm density.	1400.00	Sqft
<b>19</b>	<b>False Ceiling 4th Floor</b>		
19.1	Supplying and Erecting Saint Gobain, Gyproc gypboard false ceiling at different heights, framework of G.I. Section (of medium thickness) of spacing 4'0"x2'0" above which 12.5mm gyproc board shall be fixed. Rate shall include cut-outs for light fittings, Air Conditioners, Cove Lighting, speakers and etc.	1500	Sqft
19.2	Supply and installation of Linear LED Strip-lights (15 Watt /Metre) for installing in False-ceiling Coves together with requisite driver etc. complete as required.	200	Rft
<b>20</b>	<b>ENTRANCE MAIN DOOR</b>		

20.1	Providing and fixing Entrance door made up of 12mm toughened glass with all necessary hardware with <b>Dorma Make</b> The Side wall should be panelled with 19 MM Marine Ply with 1mm Laminate of approved shade. Entrance door should have CBIC logo Etched on glass on both the leaves. Frame finish with polishing with necessary handles. Glass edge to be machine polished	2	Sets
------	---	---	------

**LEGEND INDICATOR 4<sup>th</sup> FLOOR / 6<sup>th</sup> FLOOR**

<b>4th Floor</b>	<b>Total Area – 5000 Sq.ft</b>
<b>6th Floor</b>	<b>Total Area – 6200 Sq.ft</b>

**Annexure – C**

**UNDERTAKING BY THE BIDDER**

I/We undertake that my/our firm M/s ..... has not been **blacklisted** by any Govt. Department/Public Sector Undertaking/Autonomous Body.

2. I .....  
Son/Daughter/Wife of Shri.....  
Proprietor/Partner/Director/Authorized signatory of M/s ..... am competent to sign this declaration and execute this tender document.

3. I have carefully read and understood all the term and conditions of the tender and undertake to abide by them.

4. The information / documents furnished alongwith the above application are true and correct to the best of my knowledge and belief. I/ We, am/are well aware of the fact that furnishing of any false information / fabricated document would lead to rejection of my tender at any stage besides liabilities towards prosecution under appropriate law.

5. I/We understand that in case any deviation is found in the above statement at any stage, my/our concern/firm/co. shall be blacklisted and shall not have any dealing with the Department in future.

Date: Signature of the authorized Signatory of the firm/

Place: Company/Organization

Office Stamp/Seal:

**Annexure – D**

**Proforma of bank guarantee for performance security  
(To be stamped in accordance with stamp Act)**

Ref. No.

Date:

Bank Guarantee no.

Date:

To

The Commissioner of GST & Central Excise  
Audit-II, Chennai

Dear Sir,

In consideration of the Office of the Commissioner of GST & Central Excise, Audit-II, Chennai (hereinafter referred to as the owner , which expression shall unless repugnant to the contest or meaning there of include its successors, administrators and assigns) having awarded the contract for the supply and installation of modular furniture/work station(specification) to M/s .....with its registered office at ..... hereinafter referred to as contractor which expression shall unless repugnant to the context or meaning thereof, include its successors, administrators, executors and assigns), by letter of Award/work order no..... dated ..... and the same having been acknowledged by the contractor resulting in a contract to be executed for which the contractor having agreed to provide a contract performance guarantee for the faithful performance of the entire contract amounting to Rs..... only.

We ..... (name and address of bank) , having its head office at hereinafter referred to as the bank which expression shall, unless repugnant to the context or meaning thereof, include its successors, administrators, executors and assigns) do hereby guarantee and undertake to pay the owner, on demand any or all monies payable by the contractor to the extent of Rs..... only.

Only as aforesaid, at any time up to ..... days/month/year) without any demur, reservation, contest, recourse or protest and / or without any reference to the contractor.

Any such demand made by the owner on the bank shall be conclusive and binding notwithstanding any difference between the owner and the contractor or any dispute pending before any court, tribunal, arbitrator or any other authority. The bank undertakes not to revoke this guarantee during its currency without previous consent of the owner and further agrees that the guarantee herein contained shall continue to be enforceable till the owner discharges this guarantee.

The owner shall have the fullest liberty without affecting in any way the liability of the bank under the guarantee from time to time to extend the time for performance or the contract by the contractor. The owner shall have the fullest liberty, without affecting this guarantee, to postpone from time to time the exercise of any powers vested in them or of any right which they might have against the contractor and to exercise the same at any time in any manner, and either to enforce or to forbear to enforce any covenants, contained or implied, in the contract between the owner and the contractor or any other course or remedy or security available to the owner. The bank shall not be released to its obligation under these presents by any exercise by the owner of its liberty with reference to the matters aforesaid or any of them or by reason of any other act of omission or commission on the part of the owner or any other indulgences shown by the owner or by any other matter or thing whatsoever which under law would, but for this provisions have the effect of relieving the bank.

The bank also agrees that the owner at its option shall be entitled to enforce this guarantee against the bank as a principal debtor, in the first instance without proceeding against the contractor and notwithstanding any security or other guarantee the owner may have in relation to the contractor s liabilities.

Notwithstanding anything contained herein above our liability under this guarantee is restricted to ..... and it shall remain in force up to and including..... and shall be extended from time to time for such period not exceeding one year , as may be desired by M/s ..... on whose behalf this guarantee has been given.

Dated this ..... Day of ..... at .....

**Witness:**

-----  
(Signature)

-----  
(Signature)

-----  
(Name)

-----  
(Name)

-----  
(Official Address)

-----  
(Official Address)

Attorney as per power of Attorney no..... date..... \* \*  
\* \* \* \*

**Annexure - E1**

**PROPOSED PLAN FOR SUPPLY & INSTALLATION OF MODULAR OFFICE  
AT SIXTH FLOOR - SOUTH WING IN MHU COMPLEX, 692, ANNA SALAI,  
NANDANAM, CHENNAI-600 035**

Drawing enclosed

**Annexure - E2**

**PROPOSED PLAN FOR SUPPLY & INSTALLATION OF MODULAR OFFICE  
/ EXTENSION OF CONFERENCE HALL AT FOURTH FLOOR - NORTH  
WING IN MHU COMPLEX, 692, ANNA SALAI, NANDANAM, CHENNAI-600  
035**

Drawing enclosed



**Annexure-F**

**Instructions for Online Bid Submission:**

The bidders are required to submit soft copies of their bids electronically on the CPP Portal, using valid Digital Signature Certificates. The instructions given below are meant to assist the bidders in registering on the CPP Portal, prepare their bids in accordance with the requirements and submitting their bids online on the CPP Portal.

More information useful for submitting online bids on the CPP Portal may be obtained at: <https://eprocure.gov.in/eprocure/app>.

**REGISTRATION**

- 1) Bidders are required to enroll on the e-Procurement module of the Central Public Procurement Portal (URL: <https://eprocure.gov.in/eprocure/app>) by clicking on the link “**Online bidder Enrollment**” on the CPP Portal which is free of charge.
- 2) As part of the enrolment process, the bidders will be required to choose a unique username and assign a password for their accounts.
- 3) Bidders are advised to register their valid email address and mobile numbers as part of the registration process. These would be used for any communication from the CPP Portal.
- 4) Upon enrolment, the bidders will be required to register their valid Digital Signature Certificate (Class II or Class III Certificates with signing key usage) issued by any Certifying Authority recognized by CCA India (e.g. Sify / nCode / eMudhra etc.), with their profile.
- 5) Only one valid DSC should be registered by a bidder. Please note that the bidders are responsible to ensure that they do not lend their DSC's to others which may lead to misuse.
- 6) Bidder then logs in to the site through the secured log-in by entering their user ID / password and the password of the DSC / e-Token.

**SEARCHING FOR TENDER DOCUMENTS**

- 1) There are various search options built in the CPP Portal, to facilitate bidders to search active tenders by several parameters. These parameters could include Tender ID, Organization Name, Location, Date, Value, etc. There is also an option of advanced search for tenders, wherein the bidders may combine a number of search parameters such as Organization Name, Form of Contract, Location, Date, Other keywords etc. to search for a tender published on the CPP Portal.
- 2) Once the bidders have selected the tenders they are interested in, they may download the required documents / tender schedules. These tenders can be moved to the respective 'My Tenders' folder. This would enable the CPP Portal to intimate the bidders through SMS / e-mail in case there is any corrigendum issued to the tender document.

- 3) The bidder should make a note of the unique Tender ID assigned to each tender, in case they want to obtain any clarification / help from the Helpdesk.

**PREPARATION OF BIDS**

- 1) Bidder should take into account any corrigendum published on the tender document before submitting their bids.
- 2) Please go through the tender advertisement and the tender document carefully to understand the documents required to be submitted as part of the bid. Please note the number of covers in which the bid documents have to be submitted, the number of documents - including the names and content of each of the document that need to be submitted. Any deviations from these may lead to rejection of the bid.
- 3) Bidder, in advance, should get ready the bid documents to be submitted as indicated in the tender document / schedule and generally, they can be in PDF / XLS / RAR / DWF/JPG formats. Bid documents may be scanned with 100 dpi with black and white option which helps in reducing size of the scanned document.
- 4) To avoid the time and effort required in uploading the same set of standard documents which are required to be submitted as a part of every bid, a provision of uploading such standard documents (e.g. PAN card copy, annual reports, auditor certificates etc.) has been provided to the bidders. Bidders can use “My Space” or “Other Important Documents” area available to them to upload such documents. These documents may be directly submitted from the “My Space” area while submitting a bid, and need not be uploaded again and again. This will lead to a reduction in the time required for bid submission process.

**SUBMISSION OF BIDS**

- 1) Bidder should log into the site well in advance for bid submission so that they can upload the bid in time i.e. on or before the bid submission time. Bidder will be responsible for any delay due to other issues.
- 2) The bidder has to digitally sign and upload the required bid documents one by one as indicated in the tender document.
- 3) Bidder has to select the payment option as “offline” to pay the tender fee / EMD as applicable and enter details of the instrument.
- 4) Bidder should prepare the EMD as per the instructions specified in the tender document. The original should be posted/couriered/given in person to the concerned official, latest by the last date of bid submission or as specified in the tender documents. The details of the DD/any other accepted instrument, physically sent, should tally with the details available in the scanned copy and the data entered during bid submission time. Otherwise the uploaded bid will be rejected.
- 5) Bidders are requested to note that they should necessarily submit their financial bids in the format provided and no other format is acceptable. If the price bid has been given as a standard BoQ format with the tender

document, then the same is to be downloaded and to be filled by all the bidders. Bidders are required to download the BoQ file, open it and complete the coloured (unprotected) cells with their respective financial quotes and other details (such as name of the bidder). No other cells should be changed. Once the details have been completed, the bidder should save it and submit it online, without changing the filename. If the BoQ file is found to be modified by the bidder, the bid will be rejected.

- 6) The server time (which is displayed on the bidders' dashboard) will be considered as the standard time for referencing the deadlines for submission of the bids by the bidders, opening of bids etc. The bidders should follow this time during bid submission.
- 7) All the documents being submitted by the bidders would be encrypted using PKI encryption techniques to ensure the secrecy of the data. The data entered cannot be viewed by unauthorized persons until the time of bid opening. The confidentiality of the bids is maintained using the secured Socket Layer 128 bit encryption technology. Data storage encryption of sensitive fields is done. Any bid document that is uploaded to the server is subjected to symmetric encryption using a system generated symmetric key. Further this key is subjected to asymmetric encryption using buyers/bid opener's public keys. Overall, the uploaded tender documents become readable only after the tender opening by the authorized bid openers.
- 8) The uploaded tender documents become readable only after the tender opening by the authorized bid openers.
- 9) Upon the successful and timely submission of bids (i.e. after Clicking "Freeze Bid Submission" in the portal), the portal will give a successful bid submission message & a bid
- 10) Summary will be displayed with the bid no. and the date & time of submission of the bid with all other relevant details.
- 11) The bid summary has to be printed and kept as an acknowledgement of the submission of the bid. This acknowledgement may be used as an entry pass for any bid opening meetings.

**ASSISTANCE TO BIDDERS**

- 1) Any queries relating to the tender document and the terms and conditions contained therein should be addressed to the Tender Inviting Authority for a tender or the relevant contact person indicated in the tender.
- 2) Any queries relating to the process of online bid submission or queries relating to CPP Portal in general may be directed to the 24x7 CPP Portal Helpdesk.



Record room	1no.	Supt table	30nos. -	5'0" x 2'6"	Full Height Partition
AC's cabin	4nos.	Supt Comp table	30nos. -	3'0" x 1'6"	2810 sq.ft
Supt Cabin	30nos.	Insp table	30nos. -	4'0" x 2'0"	
Insp desk	30nos.	AC's Table	4nos. -	6'0" x 3'0"	Half Height Partition
Pantry	1no.	AC's comp Table	4nos. -	4'0" x 1'6"	2650 sq.ft
Dispatch room	1nos.				

**PROPOSED INTERIOR LAYOUT FOR GST AUDIT AT SIXTH FLOOR**  
**SOUTH WING , MHU COMPLEX , NANDANAM**  
**AREA : 6167 Sq.ft.**

Full Height Partition 3060 sq.ft  
 Wall paneling 1000 sq.ft

Half Height Partition 1620 sq.ft

Conference room 1no.  
 AC's cabin 3nos.  
 Supt Cabin 20nos.  
 Insp desk 20nos.

Supt table 20nos. - 5'0" x 2'6"  
 Supt Comp table 20nos. - 3'0" x 1'6"  
 Insp table 20nos. - 4'0" x 2'0"  
 AC's Table 3nos. - 6'0" x 3'0"  
 AC's comp Table 3nos. - 4'0" x 1'6"



PROPOSED INTERIOR LAYOUT FOR GST AUDIT AT FOURTH FLOOR  
NORTH WING , MHU COMPLEX , NANDANAM  
 AREA : 4850 Sq ft.

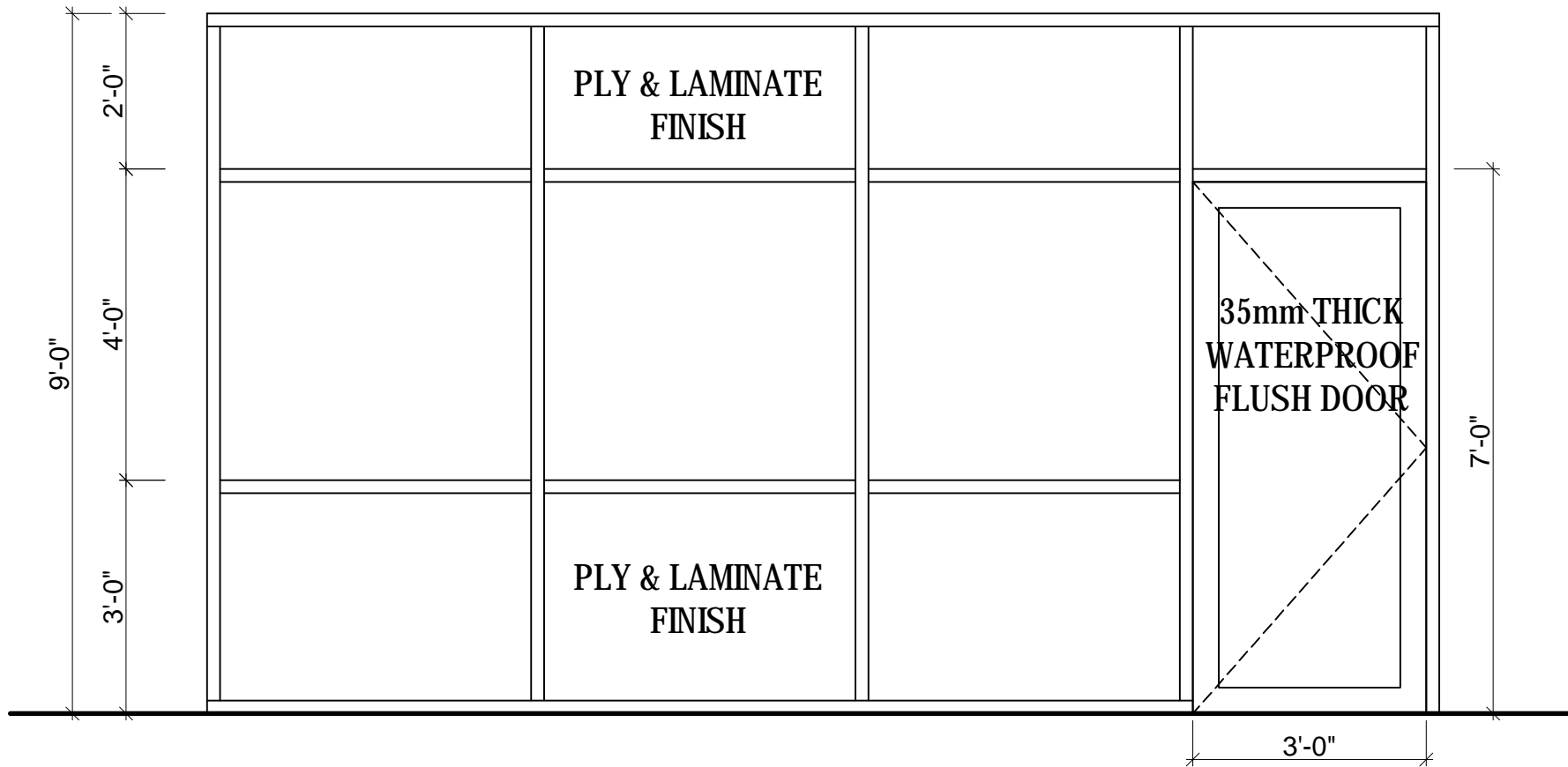

## DRAWING - A

### FULL HEIGHT PARTITION DETAIL

#### NOTES

Partition should be made of 2"x 1" Heavy duty Aluminum section with 3mm thick aluminium.

Framework grid vertically and horizontally at 2 feet spacing, should be covered with 12mm marine plywood(BWR Grade) on both sides and finished with 1mm laminate on both sides.

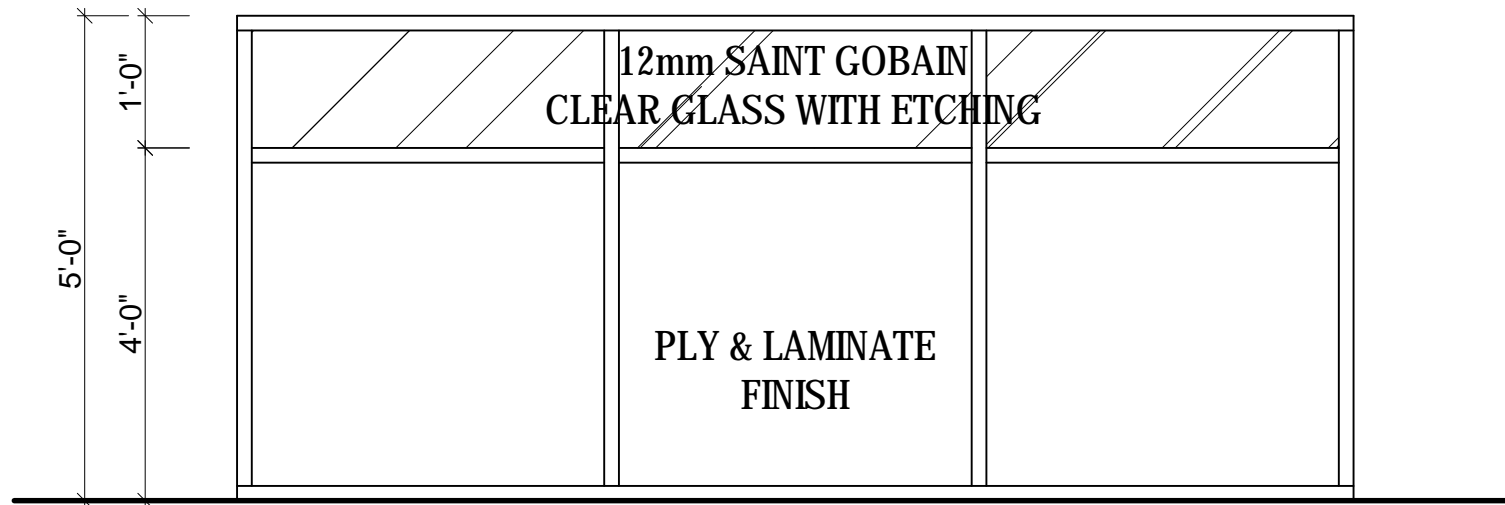

## DRAWING - B

5 feet PARTITION DETAILS ( for cubical's)

### NOTES

Partition should be made of 2" x 1" Heavy duty Aluminum section with 3mm thick aluminium.

Framework grid vertically and horizontally at 2 feet spacing, should be covered with 12mm marine plywood (BWR Grade) on both sides and pasted with 1mm laminate on both sides upto 4 feet and above that 1 feet of 12mm saint gobain clear glass with etching, should be fixed with good quality wood moulding.

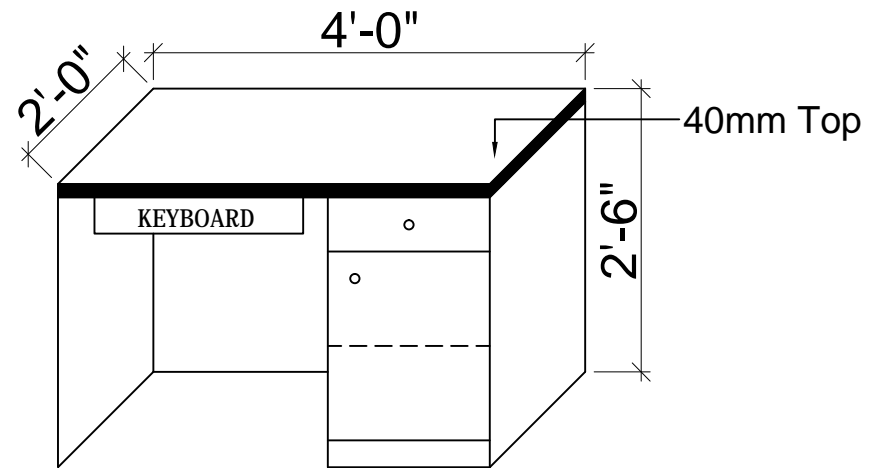

## DRAWING - C

4'0" x 2'0" TABLE

### NOTES

Table should be made from 19mm marine ply (BWR Grade) with 1mm laminate on both sides, with suitable hardware and locking arrangements. And the table top should be made of 40mm solid marine ply ( BWR Grade) finished with laminate on both sides as shown in the drawings.



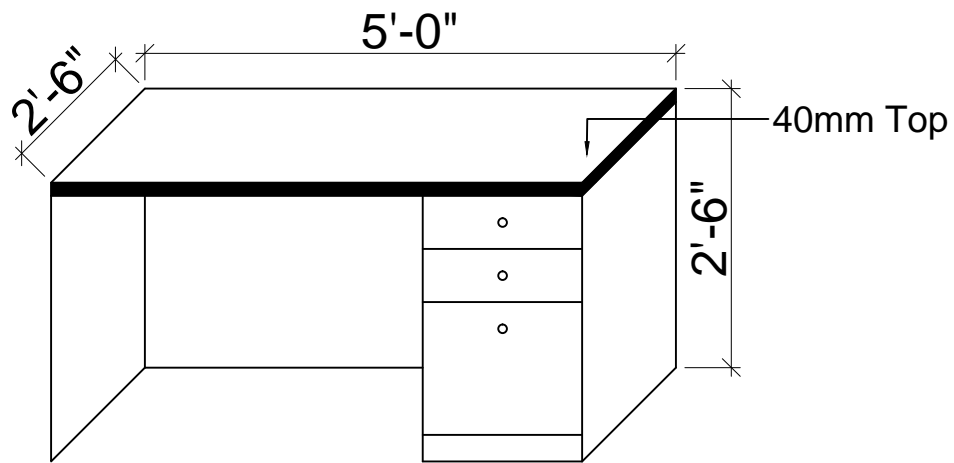

5'0" x 2'6" TABLE

DRAWING - D

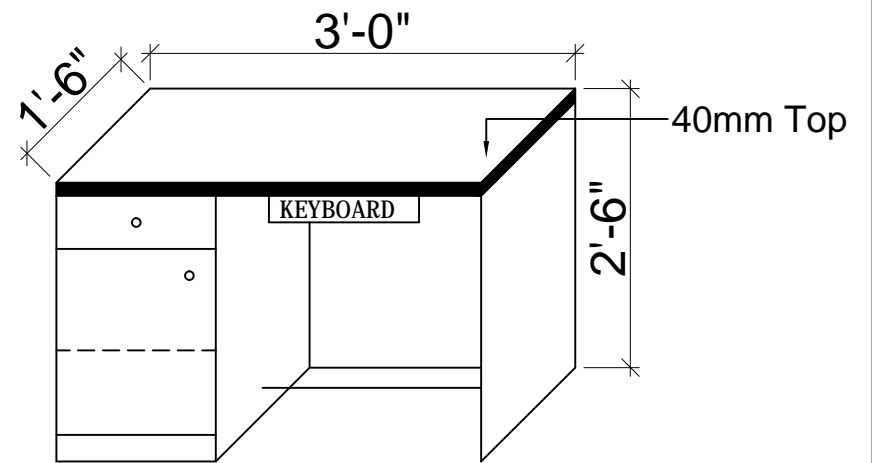

3'0" x 1'6" COMPUTER TABLE

DRAWING - E

NOTES

Table should be made from 19mm marine ply (BWR Grade) with 1mm laminate on both sides, with suitable hardware and locking arrangements. And the table top should be made of 40mm solid marine ply (BWR Grade) finished with laminate on both sides as shown in the drawings.

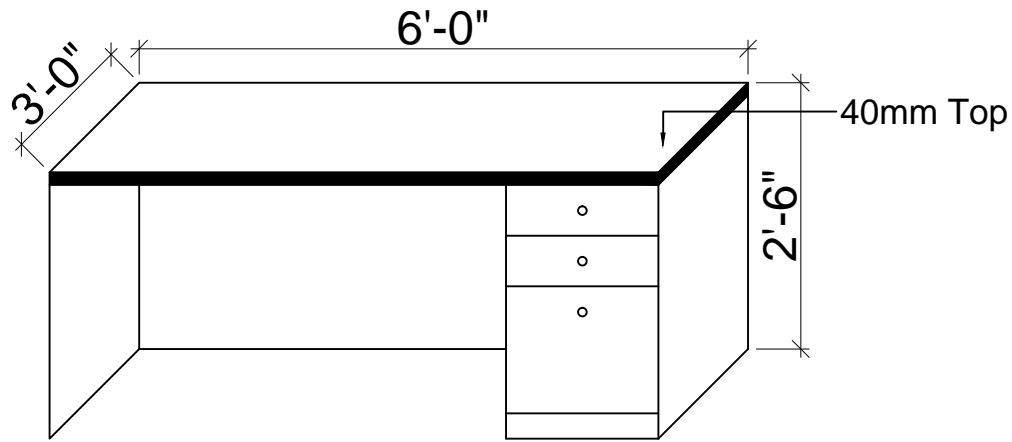

**6'0" x 3'0" TABLE**

**DRAWING - F**

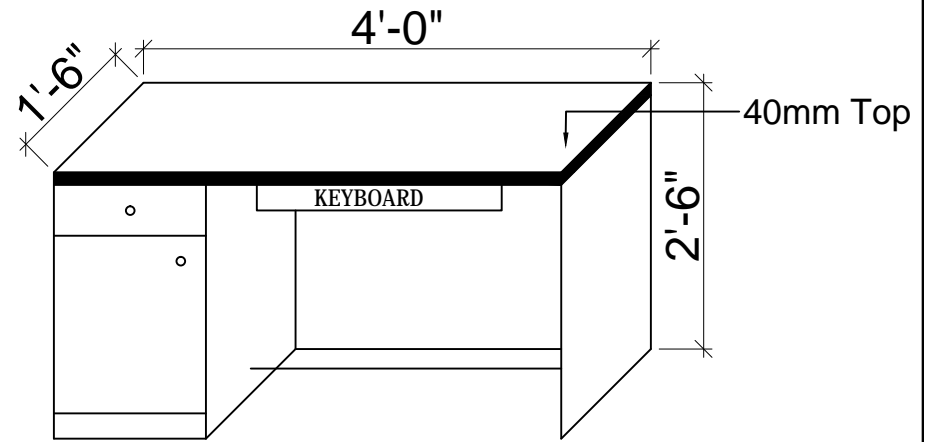

**4'0" x 1'6" COMPUTER TABLE**

**DRAWING - G**

**NOTES**

Table should be made from 19mm marine ply(BWR Grade) finished with 1mm laminate on both sides, with suitable hardware and locking arrangements. And the table top should be made of 40mm solid marine ply laminated on both sides as shown in the drawings.

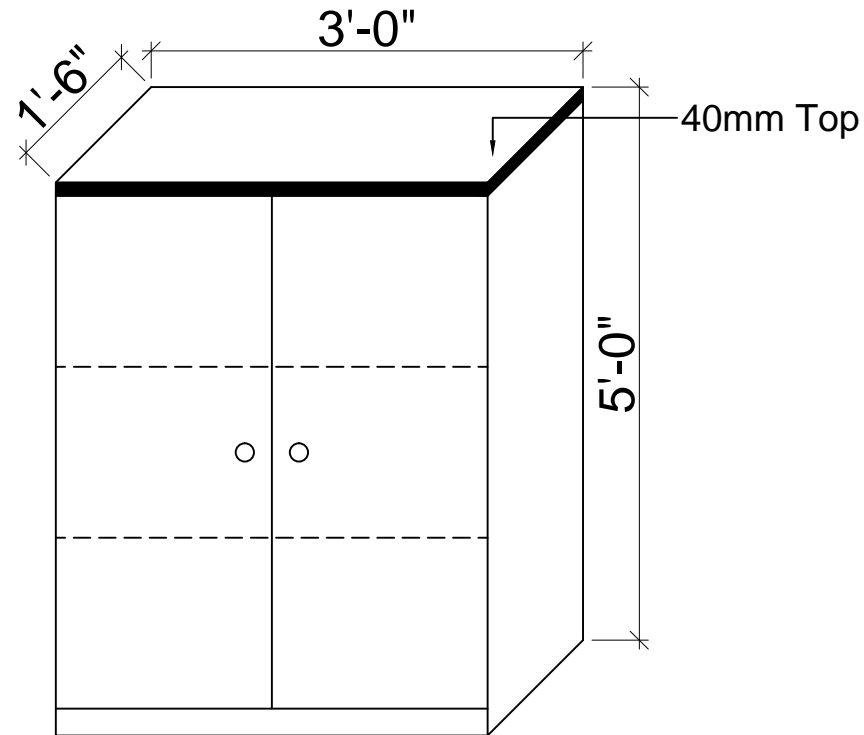

## DRAWING - H

5'0" x 3'0" STORAGE UNIT

### NOTES

Table should be made from 19mm marine ply (BWR Grade) with 1mm laminate on both sides, with suitable hardware and locking arrangements. And the table top should be made of 40mm solid marine ply (BWR Grade) finished with laminate on both sides as shown in the drawings.